

Direct current dimmable (TRAILING EDGE-LEADING EDGE) electronic drivers  
Alimentatori elettronici dimmerabili (IGBT-TRIAC) in corrente continua

Made in Europe

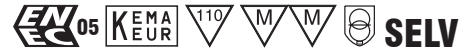

MINI MD



MINI MD BI



3.1.3

Dimmable multipower DIP-SWITCH drivers - Compact case - PHASE CUT  
Alimentatori multipotenza regolabili con DIP-SWITCH - Formato compatto - TAGLIO DI FASE

**Rated Voltage**  
Tensione Nominale  
220 ÷ 240 V

**Frequency**  
Frequenza  
50...60 Hz

**AC Operation range**  
Tensione di utilizzo AC  
198 ÷ 264 V

**Power**  
Potenza  
8 ÷ 20 W

**Output current ripple**  
≤ 20%<sup>(1)</sup>

**Reference Norms**  
Norme di riferimento  
EN 50172 (VDE 0108)

EN 55015  
EN 61000-3-2  
EN 61000-3-3  
EN 61347-1  
EN 61347-2-13  
EN 61547  
EN 62384  
VDE 0710-T14

**Max. pcs for CB B16A**  
(see page info17)  
50 pcs

**In rush current**  
2A 50μsec

Article Articolo	Code Codice	P out W	V out DC	I out DC	V out max.	ta °C	tc °C	λ Power Factor	η max. Efficiency <sup>(1)</sup>
<b>Constant current output - Uscita in corrente costante</b>									
<b>MINI MD 350</b>	127030	18	25...51	350 mA cost.	59	-25...+50	70	0,95 Pout>12W	> 89
<b>MINI MD 350 BI</b>	127031								
<b>MINI MD 500</b>	127032	21	16...42	500 mA cost.	50	-25...+45	75	0,95 Pout>13W	> 89
<b>MINI MD 500 BI</b>	127033								
<b>MINI MD 700</b>	127034	20	16...28	700 mA cost.	50	-25...+45	75	0,95 Pout>10W	> 88
<b>MINI MD 700 BI</b>	127035								

<sup>(1)</sup> Referred to  $V_m = 230$  V, 100% load - Riferito a  $V_m = 230$  V, carico 100%

**Accessories not supplied - Accessori non a corredo**

Article - Articolo	Code - Codice
ETDU29 (pag. 339)	180426
ETD2E9 (pag. 338)	180427



ETD2E9

ETDU29

### Features

- IP20 independent driver, for indoor use (MINI MD).
- Class II protection against electric shock for direct or indirect contact (MINI MD).
- Driver for built-in use (MINI MD BI).
- It can be used for lighting equipment in protection class I and II (MINI MD BI).
- Active Power Factor Corrector.
- Current regulation ±8 % including temperature variations.
- Supplied with terminal cover and cable retainer (MINI MD).
- Input and output terminal blocks on the same side (wire cross-section up to 1,5 mm<sup>2</sup> / AWG15).
- Clamping screws on primary and secondary circuits for cables with diameter: min. 3 mm - max. 8 mm (MINI MD).
- Driver can be secured with slot for screws.
- Protections:
  - against overheating and short circuits;
  - against mains voltage spikes;
  - against overloads.
- Thermal protection = C.5.a.

### Caratteristiche

- Alimentatore indipendente IP20, per uso interno (MINI MD).
- Protetto in classe II contro le scosse elettriche per contatti diretti e indiretti.
- Alimentatore da incorporare (MINI MD BI).
- Utilizzabile per apparecchi di illuminazione in classe di protezione I e II (MINI MD BI).
- PFC attivo.
- Corrente regolata ±8 % incluse variazioni di temperatura.
- Fornito di coprimorsetto e serracavo (MINI MD).
- Morsetti di entrata e uscita sullo stesso lato (sezione cavo fino a 1,5 mm<sup>2</sup> / AWG15).
- Serracavo su primario e secondario per cavi di diametro: min. 3 mm - max. 8 mm (MINI MD).
- Fissaggio dell'alimentatore tramite asole per viti.
- Protezioni:
  - termica e cortocircuito;
  - contro le extra-tensioni di rete;
  - contro i sovraccarichi.
- Protezione termica = C.5.a.



**Direct current dimmable (TRAILING EDGE-LEADING EDGE) electronic drivers**  
**Alimentatori elettronici dimmerabili (IGBT-TRIAC) in corrente continua**

Made in Europe



**IP 20**



Ø55  
2.17"



Weight - Peso gr. 108 / 3,50 oz.  
Pcs - Pezzi 50

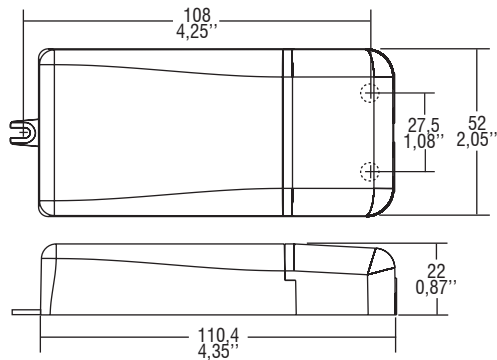

**BUILT-IN**  
**SCREW**  
**FIXING**

Weight - Peso gr. 100 / 3,50 oz.  
Pcs - Pezzi 50

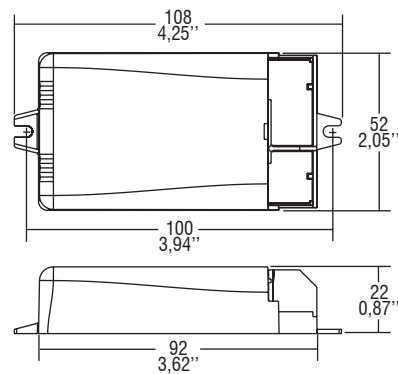

**Wiring diagram - Schema di collegamento** (Max. LED distance on page info8 - Massima distanza LED a pagina info8)

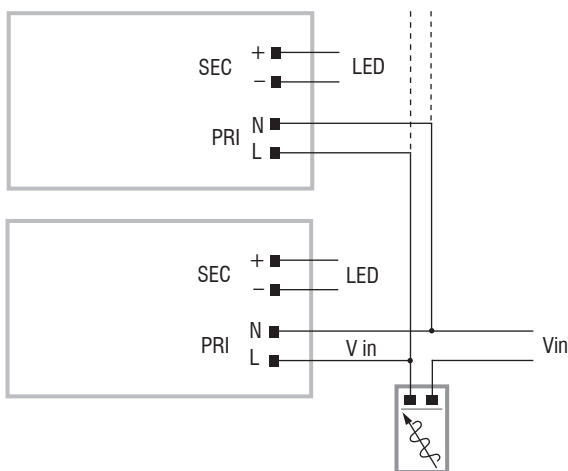

**3.1.3**

Dimmable multipower DIP-SWITCH drivers - Compact case - PHASE CUT  
Alimentatori multipotenza regolabili con DIP-SWITCH - Formato compatto - TAGLIO DI FASE